



BUCK-BOOST TRANSFORMERS



Buck-Boost Transformers

Why use Buck-Boost transformers?

The advantages of using a buck-boost transformer over an equivalent standard isolation transformer are:

Advantages

1. Used in a variety of applications
2. Inexpensive and stocked voltage correction
3. Smaller and lighter than an isolation transformer

Disadvantages

1. No circuit isolation
2. Cannot create a neutral
3. KVA and voltages do not match what's on the nameplate
kVA and voltages.



Why use Buck-Boost transformers?

Buck-boost transformers offer an economical solution to the adjustment of line voltages that are slightly above or below normal. When a buck-boost transformer is connected as an autotransformer, only a portion of the load kVA is actually transformed. The majority of the load kVA is passed directly through to the source. For this reason a buck-boost transformer may be used to supply a much larger kVA load than is indicated on the nameplate.

Buck-boost transformers can be used to adjust stable voltages only.

Standard Specification

	50 to 1000 VA	1500 to 5000 VA
UL Listed:	File: E50394	File: E50394
CSA Certified:	File: LR3902	File: LR3902
Frequency:	50/60 Hz	50/60 Hz
Insulation System:	130°C (80°C rise)	180°C (115°C rise)
Standard Design:	Single phase, welded core construction made with high quality, high permeability silicon steel laminations. Computer designed coils are accurately wound from high quality copper magnetic wire.	Single phase, welded core construction made with high quality, high permeability silicon steel laminations. Computer designed coils are accurately wound from high quality copper magnetic wire.
Encapsulation:	All units are encapsulated with electrical grade silica sand and resin compounds	All units from 50VA to 5kVA are encapsulated with electrical grade silica sand and resin compounds
Enclosure Type:	Heavy duty encapsulated type 3R optional type 4, 4X (stainless) & 12 available	Heavy duty encapsulated type 3R optional type 4, 4X (stainless) & 12 available
Enclosure Finish:	ANSI 61 Grey, UL50	ANSI 61 Grey, UL50
Termination:	Front accessible separate high and low voltage lead wires or copper tabs	Front accessible separate high and low voltage lead wires or copper tabs
Conduit Knock-Outs:	Side and rear standard on all units (no knock-outs on Stainless Steel enclosures)	Side and rear standard on all units (no knock-outs on Stainless Steel enclosures)
Mounting:	Standard Wall Mounting	Standard Wall Mounting

Voltage is the key

Buck-boost transformers represent an economical way to both raise supply voltage caused by line drop or equipment demand on the distribution system, or lower voltage caused by increased system voltages due to supply line adjustments. Some loads including lighting and resistive loads require a stable supply to maintain performance. The detrimental effects of incorrect supply line voltage can cause equipment failure. Buck-boost transformers can correct line voltage within 5 to 25% of nominal.

Step for selecting Buck-Boost transformers

The following information is required before selecting a buck-boost transformer:

1. Line Voltage - The voltage that you want to buck (decrease) or boost (increase). This can be determined by measuring the supply line voltage with a voltmeter.
2. Load Voltage - The voltage at which your equipment is designed to operate. This is listed on the nameplate of the load equipment.
3. Load kVA or Load Amps - You do not need to know both - one or the other is sufficient. This information usually can be found on the nameplate of the equipment that you want to operate. It is the sum of all the equipment that represents the load.
4. Frequency - The supply line frequency must be the same as the equipment to be operated - either 50 or 60 Hertz.
5. Phase - The supply line should be the same as the load - either single or three phase.

HPS Buck-Boost Transformer Part Number Guide

Example

Product Family		Kva		Primary & Secondary Voltages		Winding Material/ Electrostatic Shield	Temp. Rise
Q	C	2	5	E	R	K	B
Product Line:				Primary:	Secondary:	Winding Material:	
Q - Buck-Boost Transformer				120/240	12/24	C = Copper	
kVA Rating:				120/240	16/32	K = CU + Shield	
kVA	P/N			240/480	24/48	Temperature Rise:	
0.05	= C05					B = 80°C Rise	
0.10	= C10					F = 115°C Rise (180°C Class)	
0.15	= C15						
0.20	= C20						
0.25	= C25						
0.35	= C35						
0.50	= C50						
0.75	= C75						
1.0	= 1C0						
1.5	= 1C5						
2	= 002						
3	= 003						
5	= 005						
				P/N Suffix:			
				ER			
				ES			
				DT			

SELECTION CHARTS

SINGLE PHASE - GROUP A

1. From the top row of the "Selection Chart" locate the high and low voltage combination that is closest to the one you require.
2. Move down that column to the kVA or Ampere rating equal to or greater than the rating required by the load.
3. From the far left column, obtain the transformer catalog number.
4. For dimensional information refer to the specifications table (Group A) on page 10.
5. The corresponding connection diagram is indicated at the bottom of the Voltage / kVA column.



120 X 240 PRIMARY VOLTS		12 X 24 SECONDARY VOLTS														50/60 HZ	
Catalog Number	Low Voltage	96	100	100	105	110	110	115	115	120	120	200	208	220	220	240	240
	High Voltage	115	110	120	115	121	132	126	138	132	144	220	229	231	242	252	264
QC05ERCB	HV Amps	2.08	4.17	2.08	4.17	4.17	2.08	4.17	2.08	4.17	2.08	2.08	2.08	4.17	2.08	4.17	2.08
	KVA	.240	.458	.250	.480	.504	.275	.526	.288	.550	.300	.458	.477	.963	.504	1.05	.550
	LV Amps	2.50	4.58	2.50	4.58	4.58	2.50	4.58	2.50	4.58	2.50	2.29	2.29	4.38	2.29	4.38	2.29
QC10ERCB	HV Amps	4.17	8.33	4.17	8.33	8.33	4.17	8.33	4.17	8.33	4.17	4.17	4.17	8.33	4.17	8.33	4.17
	KVA	.480	.917	.500	.961	1.01	.550	1.05	.575	1.10	.600	.917	.953	1.92	1.01	2.10	1.10
	LV Amps	5.00	9.17	5.00	9.17	9.17	5.00	9.17	5.00	9.17	5.00	4.58	4.58	8.75	4.58	8.75	4.58
QC15ERCB	HV Amps	6.25	12.5	6.25	12.5	12.5	6.25	12.5	6.25	12.5	6.25	6.25	6.25	12.5	6.25	12.5	6.25
	KVA	.720	1.38	.750	1.44	1.51	.825	1.58	.863	1.65	.900	1.38	1.43	2.88	1.51	3.15	1.65
	LV Amps	7.50	13.8	7.50	13.8	13.8	7.50	13.8	7.50	13.8	7.50	6.88	6.88	13.1	6.88	13.1	6.88
QC20ERCB	HV Amps	8.33	16.7	8.33	16.7	16.7	8.33	16.7	8.33	16.7	8.33	8.33	8.33	16.7	8.33	16.7	8.33
	KVA	.960	1.83	1.00	1.92	2.02	1.10	2.11	1.15	2.20	1.20	1.83	1.91	3.85	2.02	4.20	2.20
	LV Amps	10.0	18.3	10.0	18.3	18.3	10.0	18.3	10.0	18.3	10.0	9.17	9.17	17.5	9.17	17.5	9.17
QC25ERCB	HV Amps	10.4	20.8	10.4	20.8	20.8	10.4	20.8	10.4	20.8	10.4	10.4	10.4	20.8	10.4	20.8	10.4
	KVA	1.20	2.29	1.25	2.40	2.52	1.37	2.63	1.44	2.75	1.50	2.29	2.38	4.81	2.52	5.25	2.75
	LV Amps	12.5	22.9	12.5	22.9	22.9	12.5	22.9	12.5	22.9	12.5	11.4	11.4	21.8	11.4	21.8	11.4
QC35ERCB	HV Amps	14.6	29.2	14.6	29.2	29.2	14.6	29.2	14.6	29.2	14.6	14.6	14.6	29.2	14.6	29.2	14.6
	KVA	1.68	3.21	1.75	3.36	3.53	1.92	3.68	2.01	3.85	2.10	3.21	3.34	6.74	3.53	7.35	3.85
	LV Amps	17.5	32.1	17.5	32.1	32.1	17.5	32.1	17.5	32.1	17.5	16.0	16.0	30.6	16.0	30.6	16.0
QC50ERCB	HV Amps	20.8	41.6	20.8	41.7	41.7	20.8	41.7	20.8	41.7	20.8	20.8	20.8	41.7	20.8	41.7	20.8
	KVA	2.39	4.58	2.50	4.80	5.04	2.75	5.26	2.87	5.50	3.00	4.58	4.77	9.62	5.04	10.5	5.50
	LV Amps	24.9	45.8	25.0	45.8	45.8	25.0	45.8	25.0	45.8	25.0	22.9	22.9	43.7	22.9	43.7	22.9
QC75ERCB	HV Amps	31.2	62.5	31.2	62.5	62.5	31.2	62.5	31.2	62.5	31.2	31.2	31.2	62.5	31.2	62.5	31.2
	KVA	3.60	6.87	3.75	7.20	7.56	4.12	7.89	4.31	8.25	4.50	6.87	7.15	14.4	7.56	15.7	8.25
	LV Amps	37.5	68.7	37.5	68.7	68.7	37.5	68.7	37.5	68.7	37.5	34.4	34.4	65.6	34.4	65.6	34.4
Q1C0ERCB	HV Amps	41.7	83.3	41.7	83.3	83.3	41.7	83.3	41.7	83.3	41.7	41.7	41.7	83.3	41.7	83.3	41.7
	KVA	4.80	9.17	5.00	9.60	10.1	5.50	10.5	5.75	11.0	6.00	9.17	9.53	19.2	10.1	21.0	11.0
	LV Amps	50.0	91.7	50.0	91.7	91.7	50.0	91.7	50.0	91.7	50.0	45.8	45.8	87.5	45.8	87.5	45.8
Q1C5ERCF	HV Amps	62.5	125	62.5	125	125	62.5	125	62.5	125	62.5	62.5	62.5	125	62.5	125	62.5
	KVA	7.20	13.7	7.50	14.4	15.1	8.25	15.8	8.62	16.5	9.00	13.7	14.3	28.9	15.1	31.5	16.5
	LV Amps	75.0	137	75.0	137	137	75.0	137	75.0	137	75.0	68.7	68.8	131	68.7	131	68.7
Q002ERCF	HV Amps	83.3	166	83.3	166	166	83.3	166	83.3	166	83.3	83.3	83.3	166	83.3	166	83.3
	KVA	9.58	18.3	10.0	19.2	20.1	11.0	21.0	11.5	22.0	12.0	18.3	19.0	38.5	20.1	42.0	22.0
	LV Amps	99.8	183	100	183	183	100	183	100	183	100	91.7	91.7	175	91.6	175	91.6
Q003ERCF	HV Amps	125	250	125	250	250	125	250	125	250	125	125	125	250	125	250	125
	KVA	14.4	27.5	15.0	28.8	30.2	16.5	31.5	17.2	33.0	18.0	27.5	28.6	57.7	30.2	63.0	33.0
	LV Amps	150	275	150	275	275	150	275	150	275	150	137	137	262	137	262	137
Q005ERCF	HV Amps	208	417	208	417	417	208	417	208	417	208	208	208	417	208	417	208
	KVA	24.0	45.8	25.0	48.0	50.4	27.5	52.7	28.7	55.0	30.0	45.8	47.7	96.3	50.4	105	55.0
	LV Amps	250	458	250	458	458	250	458	250	458	250	229	229	438	229	438	229
CONNECTION DIAGRAM		2	1	2	1	1	2	1	2	1	2	4	4	3	4	3	4

SELECTION CHARTS

SINGLE PHASE - GROUP B

1. From the top row of the "Selection Chart" locate the high and low voltage combination that is closest to the one you require.
2. Move down that column to the kVA or Ampere rating equal to or greater than the rating required by the load.
3. From the far left column, obtain the transformer catalog number.
4. For dimensional information refer to the specifications table (Group B) on page 10.
5. The corresponding connection diagram is indicated at the bottom of the Voltage / kVA column.



120 X 240 PRIMARY VOLTS		16 X 32 SECONDARY VOLTS														50/60 HZ	
Catalog Number	Low Voltage	95	101	106	110	110	115	115	120	120	203	208	220	220	230	240	240
	High Voltage	120	115	120	125	139	130	146	136	152	230	236	235	249	261	256	272
QC05ESCB	HV Amps	1.56	3.13	3.13	3.13	1.56	3.13	1.56	3.13	1.56	1.56	1.56	3.13	1.56	1.56	3.13	1.56
	KVA	.188	.359	.375	.390	.218	.407	.228	.425	.238	.359	.368	.733	.390	.407	.800	.425
	LV Amps	1.98	3.54	3.54	3.54	1.98	3.54	1.98	3.54	1.98	1.77	1.77	3.33	1.77	1.77	3.33	1.77
QC10ESCB	HV Amps	3.12	6.25	6.25	6.25	3.12	6.25	3.12	6.25	3.12	3.12	3.12	6.25	3.12	3.12	6.25	3.12
	KVA	.376	.718	.751	.779	.435	.815	.455	.850	.475	.719	.737	1.47	.779	.815	1.60	.850
	LV Amps	3.96	7.08	7.08	7.08	3.96	7.08	3.96	7.08	3.96	3.54	3.54	6.67	3.54	3.54	6.67	3.54
QC15ESCB	HV Amps	4.69	9.38	9.38	9.38	4.69	9.38	4.69	9.38	4.69	4.69	4.69	9.38	4.69	4.69	9.38	4.69
	KVA	.564	1.07	1.13	1.17	.653	1.22	.683	1.28	.713	1.08	1.10	2.20	1.17	1.22	2.40	1.28
	LV Amps	5.94	10.6	10.6	10.6	5.94	10.6	5.94	10.6	5.94	5.31	5.31	10.0	5.31	5.31	10.0	5.31
QC20ESCB	HV Amps	6.25	12.5	12.5	12.5	6.25	12.5	6.25	12.5	6.25	6.25	6.25	12.5	6.25	6.25	12.5	6.25
	KVA	.752	1.43	1.50	1.56	0.871	1.63	0.91	1.70	.950	1.44	1.47	2.93	1.56	1.63	3.20	1.70
	LV Amps	7.92	14.2	14.2	14.2	7.92	14.2	7.92	14.2	7.92	7.08	7.08	13.3	7.08	7.08	13.3	7.08
QC25ESCB	HV Amps	7.81	15.6	15.6	15.6	7.81	15.6	7.81	15.6	7.81	7.81	7.81	15.6	7.81	7.81	15.6	7.81
	KVA	0.94	1.80	1.87	1.95	1.09	2.04	1.14	2.12	1.19	1.80	1.84	3.67	1.95	2.04	4.00	2.12
	LV Amps	9.90	17.7	17.7	17.7	9.87	17.7	9.90	17.7	9.90	8.85	8.85	16.7	8.85	8.85	16.7	8.85
QC35ESCB	HV Amps	10.9	21.9	21.9	21.9	10.9	21.9	10.9	21.9	10.9	10.9	10.9	21.9	10.9	10.9	21.9	10.9
	KVA	1.31	2.51	2.63	2.73	1.52	2.85	1.59	2.98	1.66	2.51	2.58	5.13	2.73	2.85	5.60	2.98
	LV Amps	13.9	24.8	24.8	24.8	13.9	24.8	13.9	24.8	13.9	12.4	12.4	23.3	12.4	12.4	23.3	12.4
QC50ESCB	HV Amps	15.6	31.2	31.2	31.2	15.6	31.2	15.6	31.2	15.6	15.6	15.6	31.2	15.6	15.6	31.2	15.6
	KVA	1.88	3.59	3.75	3.90	2.18	4.07	2.28	4.25	2.37	3.59	3.68	7.33	3.90	4.07	8.00	4.25
	LV Amps	19.8	35.4	35.4	35.4	19.8	35.4	19.8	35.4	19.8	17.7	17.7	33.3	17.7	17.7	33.3	17.7
QC75ESCB	HV Amps	23.4	46.8	46.8	46.9	23.4	46.9	23.4	46.9	23.4	23.4	23.4	46.9	23.4	23.4	46.9	23.4
	KVA	2.82	5.39	5.63	5.84	3.27	6.10	3.41	6.37	3.56	5.39	5.53	11.0	5.84	6.11	12.0	6.37
	LV Amps	29.7	53.1	53.1	53.1	29.7	53.1	29.7	53.1	29.7	26.6	26.6	50.0	26.6	26.6	50.0	26.6
Q1C0ESCB	HV Amps	31.2	62.5	62.5	62.5	31.2	62.5	31.2	62.5	31.2	31.2	31.2	62.5	31.2	31.2	62.5	31.2
	KVA	3.76	7.18	7.50	7.79	4.35	8.15	4.55	8.50	4.75	7.19	7.37	14.7	7.79	8.15	16.0	8.50
	LV Amps	39.6	70.8	70.8	70.8	39.6	70.8	39.6	70.8	39.6	35.4	35.4	66.7	35.4	35.4	66.7	35.4
Q1C5ESCF	HV Amps	46.9	93.7	93.7	93.7	46.9	93.7	46.9	93.7	46.9	46.9	46.8	93.7	46.9	46.9	93.7	46.9
	KVA	5.64	10.8	11.2	11.7	6.53	12.2	6.83	12.7	7.12	10.8	11.0	22.0	11.7	12.2	24.0	12.7
	LV Amps	59.4	106	106	106	59.4	106	59.4	106	59.4	53.1	53.1	100	53.1	53.1	100	53.1
Q002ESCF	HV Amps	62.5	125	125	125	62.5	125	62.5	125	62.5	62.5	62.5	125	62.5	62.5	125	62.5
	KVA	7.50	14.4	15.0	15.6	8.71	16.3	9.10	17.0	9.50	14.4	14.7	29.3	15.6	16.3	32.0	17.0
	LV Amps	79.1	142	142	142	79.2	142	79.2	142	79.2	70.8	70.8	133	70.8	70.8	133	70.8
Q003ESCF	HV Amps	93.7	187	187	187	93.7	187	93.7	187	93.7	93.7	93.7	187	93.7	93.7	187	93.7
	KVA	11.3	21.5	22.5	23.4	13.0	24.4	13.6	25.5	14.2	21.6	22.1	44.0	23.4	24.4	48.0	25.5
	LV Amps	119	212	212	212	119	212	119	212	119	106	106	200	106	106	200	106
Q005ESCF	HV Amps	156	312	312	312	156	312	156	312	156	156	156	312	156	156	313	156
	KVA	18.8	35.9	37.5	39.0	21.8	40.7	22.8	42.5	23.8	35.9	36.8	73.3	39.0	40.7	80.0	42.5
	LV Amps	198	354	354	354	198	354	198	354	198	177	177	333	177	177	333	177
CONNECTION DIAGRAM		2	1	1	1	2	1	2	1	2	4	4	3	4	4	3	4

SELECTION CHARTS

SINGLE PHASE - GROUP C

1. From the top row of the "Selection Chart" locate the high and low voltage combination that is closest to the one you require.
2. Move down that column to the kVA or Ampere rating equal to or greater than the rating required by the load.
3. From the far left column, obtain the transformer catalog number.
4. For dimensional information refer to the specifications table (Group C) on page 10.
5. The corresponding connection diagram is indicated at the bottom of the Voltage / kVA column.



240 X 480 PRIMARY VOLTS		24 X 48 SECONDARY VOLTS														50/60 HZ	
Catalog Number	Low Voltage	200	208	220	230	240	380	416	430	435	436	440	440	450	456	460	480
	High Voltage	220	229	242	276	264	418	458	473	457	480	462	484	473	479	483	504
QC05DTCB	HV Amps	2.08	2.08	2.08	1.04	2.08	1.04	1.04	1.04	2.08	1.04	2.08	1.04	2.08	2.08	2.08	2.08
	KVA	0.46	0.48	0.50	0.29	0.55	0.44	0.48	0.49	0.95	0.50	0.96	0.50	0.98	1.00	1.01	1.05
	LV Amps	2.29	2.29	2.29	1.25	2.29	1.15	1.15	1.15	2.19	1.15	2.19	1.15	2.19	2.19	2.19	2.19
QC10DTCB	HV Amps	4.17	4.17	4.17	2.08	4.17	2.08	2.08	2.08	4.17	2.08	4.17	2.08	4.17	4.17	4.17	4.17
	KVA	0.92	0.95	1.01	0.58	1.10	0.87	0.95	0.99	1.90	1.00	1.93	1.01	1.97	2.00	2.01	2.10
	LV Amps	4.58	4.58	4.58	2.50	4.58	2.29	2.29	2.29	4.38	2.29	4.38	2.29	4.38	4.38	4.38	4.38
QC15DTCB	HV Amps	6.25	6.25	6.25	3.13	6.25	3.13	3.13	3.13	6.25	3.13	6.25	3.13	6.25	6.25	6.25	6.25
	KVA	1.38	1.43	1.51	0.86	1.65	1.31	1.43	1.48	2.85	1.50	2.89	1.51	2.95	2.99	3.02	3.15
	LV Amps	6.88	6.88	6.88	3.75	6.88	3.44	3.44	3.44	6.56	3.44	6.56	3.44	6.56	6.56	6.56	6.56
QC20DTCB	HV Amps	8.33	8.33	8.33	4.17	8.33	4.17	4.17	4.17	8.33	4.17	8.33	4.17	8.33	8.33	8.33	8.33
	KVA	1.83	1.91	2.02	1.15	2.20	1.74	1.91	1.97	3.81	2.00	3.85	2.02	3.94	3.99	4.03	4.20
	LV Amps	9.17	9.17	9.17	5.00	9.17	4.58	4.58	4.58	8.75	4.58	8.75	4.58	8.75	8.75	8.75	8.75
QC25DTCB	HV Amps	10.4	10.4	10.4	5.21	10.4	5.21	5.21	5.21	10.4	5.21	10.4	5.21	10.4	10.4	10.4	10.4
	KVA	2.29	2.38	2.52	1.44	2.75	2.18	2.38	2.46	4.76	2.50	4.81	2.52	4.92	4.99	5.03	5.25
	LV Amps	11.5	11.5	11.5	6.3	11.5	5.73	5.73	5.73	10.9	5.73	10.9	5.73	10.9	10.9	10.9	10.9
QC35DTCB	HV Amps	14.6	14.6	14.6	7.3	14.6	7.3	7.3	7.3	14.6	7.3	14.6	7.3	14.6	14.6	14.6	14.6
	KVA	3.21	3.34	3.53	2.01	3.85	3.05	3.34	3.45	6.61	3.50	6.74	3.53	6.89	6.98	7.0	7.4
	LV Amps	16.0	16.0	16.0	8.8	16.0	8.0	8.0	8.0	15.3	8.0	15.3	8.0	15.3	15.3	15.3	15.3
QC50DTCB	HV Amps	20.8	20.8	20.8	10.4	20.8	10.4	10.4	10.4	20.8	10.4	20.8	10.4	20.8	20.8	20.8	20.8
	KVA	4.58	4.77	5.04	2.88	5.5	4.35	4.77	4.93	9.52	5.00	9.63	5.04	9.84	9.98	10.1	10.5
	LV Amps	22.9	22.9	22.9	12.5	22.9	11.5	11.5	11.5	21.9	11.5	21.9	11.5	21.9	21.9	21.9	21.9
QC75DTCB	HV Amps	31.3	31.3	31.3	15.6	31.3	15.6	15.6	15.6	31.3	15.6	31.3	15.6	31.3	31.3	31.3	31.3
	KVA	6.88	7.15	7.56	4.31	8.25	6.53	7.15	7.39	14.3	7.49	14.4	7.56	14.8	15.0	15.1	15.8
	LV Amps	34.4	34.4	34.4	18.8	34.4	17.2	17.2	17.2	32.8	17.2	32.8	17.2	32.8	32.8	32.8	32.8
Q1C0DTCB	HV Amps	41.7	41.7	41.7	20.8	41.7	20.8	20.8	20.8	41.7	20.8	41.7	20.8	41.7	41.7	41.7	41.7
	KVA	9.17	9.53	10.1	5.75	11	8.71	9.53	9.85	19.0	9.99	19.3	10.1	19.7	20.0	20.1	21.0
	LV Amps	45.8	45.8	45.8	25.0	45.8	22.9	22.9	22.9	43.8	22.9	43.8	22.9	43.8	43.8	43.8	43.8
Q1C5DTCF	HV Amps	62.5	62.5	62.5	31.3	62.5	31.3	31.3	31.3	62.5	31.3	62.5	31.3	62.5	62.5	62.5	62.5
	KVA	13.8	14.3	15.1	8.6	16.5	13.1	14.3	14.8	28.5	15.0	28.9	15.1	29.5	29.9	30.2	31.5
	LV Amps	68.8	68.8	68.8	37.5	68.8	34.4	34.4	34.4	65.6	34.4	65.6	34.4	65.6	65.6	65.6	65.6
Q002DTCF	HV Amps	83.3	83.3	83.3	41.7	83.3	41.7	41.7	41.7	83.3	41.7	83.3	41.7	83.3	83.3	83.3	83.3
	KVA	18.3	19.1	20.2	11.5	22.0	17.4	19.1	19.7	38.1	20.0	38.5	20.2	39.4	39.9	40.3	42.0
	LV Amps	91.7	91.7	91.7	50.0	91.7	45.8	45.8	45.8	87.5	45.8	87.5	45.8	87.5	87.5	87.5	87.5
Q003DTCF	HV Amps	125	125	125	62.5	125	62.5	62.5	62.5	125	62.5	125	62.5	125	125	125	125
	KVA	27.5	28.6	30.3	17.3	33	26.1	28.6	29.6	57.1	30.0	57.8	30.3	59.1	59.9	60.4	63.0
	LV Amps	138	138	138	75	138	68.8	68.8	68.8	131	68.8	131	68.8	131	131	131	131
Q005DTCF	HV Amps	208	208	208	104	208	104	104	104	208	104	208	104	208	208	208	208
	KVA	45.8	47.7	50.4	28.8	55.0	43.5	47.7	49.3	95.2	50.0	96.3	50.4	98.4	99.8	101	105
	LV Amps	229	229	229	125	229	115	115	115	219	115	219	115	219	219	219	219
CONNECTION DIAGRAM		1	1	1	2	1	4	4	4	3	4	3	4	3	3	3	3

SELECTION CHARTS

THREE PHASE - GROUP A

1. From the top row of the "Selection Chart" locate the high and low voltage combination that is closest to the one you require.
2. Determine the quantity you required.
3. The corresponding connection diagram is indicated at the top of the Voltage / kVA column.
4. Move down that column to the kVA or Ampere rating equal to or greater than the rating required by the load.
5. From the far left column, obtain the transformer catalog number.
6. For dimensional information refer to the specifications table (Group A) on page 11.



120 X 240 PRIMARY VOLTS		12 X 24 SECONDARY VOLTS										50/60 HZ				
Catalog Number	Low Voltage	189	198	208	208	220	227	228	232	240	189	199	208	379	416	416
	High Voltage	208	208	218	229	242	250	239	255	264	208	239	229	417	436	457
QUANTITY REQUIRED		2	2	2	2	2	2	2	2	2	3	3	3	3	3	3
CONNECTION DIAGRAM		7	8	8	7	7	7	8	7	7	10	9	10	12	11	12
Three Phase Connection Stle		Delta Connected										Wye Connected				
QC05ERCB	HV Amps	2.08	4.17	4.17	2.08	2.08	2.08	4.17	2.08	2.08	4.17	2.08	4.17	2.08	4.17	2.08
	KVA	0.76	1.51	1.58	0.83	0.88	0.91	1.73	0.93	0.96	1.50	0.86	1.65	1.51	3.15	1.65
	LV Amps	2.29	4.38	4.38	2.29	2.29	2.29	4.38	2.29	2.29	4.58	2.50	4.58	2.29	4.38	2.29
QC10ERCB	HV Amps	4.17	8.33	8.33	4.17	4.17	4.17	8.33	4.17	4.17	8.33	4.17	8.33	4.17	8.33	4.17
	KVA	1.51	3.01	3.16	1.66	1.75	1.81	3.46	1.85	1.91	3.00	1.73	3.30	3.01	6.30	3.30
	LV Amps	4.58	8.75	8.75	4.58	4.58	4.58	8.75	4.58	4.58	9.17	5.00	9.17	4.58	8.75	4.58
QC15ERCB	HV Amps	6.25	12.50	12.50	6.25	6.25	6.25	12.50	6.25	6.25	12.5	6.25	12.5	6.25	12.50	6.25
	KVA	2.26	4.51	4.73	2.48	2.62	2.71	5.19	2.77	2.86	4.50	2.59	4.95	4.52	9.45	4.95
	LV Amps	6.88	13.10	13.10	6.88	6.88	6.88	13.10	6.88	6.88	13.8	7.50	13.8	6.88	13.1	6.88
QC20ERCB	HV Amps	8.33	16.70	16.70	8.33	8.33	8.33	16.70	8.33	8.33	16.7	8.33	16.7	8.33	16.70	8.33
	KVA	3.01	6.01	6.31	3.31	3.50	3.61	6.92	3.69	3.82	6.00	3.45	6.60	6.03	12.6	6.60
	LV Amps	9.17	17.50	17.50	9.17	9.17	9.17	17.50	9.17	9.17	18.3	10.0	18.3	9.17	17.5	9.17
QC25ERCB	HV Amps	10.4	20.8	20.8	10.4	10.4	10.4	20.8	10.4	10.4	20.8	10.4	20.8	10.4	20.8	10.4
	KVA	3.76	7.51	7.89	4.13	4.37	4.51	8.64	4.61	4.77	7.50	4.31	8.25	7.53	15.75	8.25
	LV Amps	11.5	21.9	21.9	11.5	11.5	11.5	21.9	11.5	11.5	22.9	12.5	22.9	11.5	21.9	11.5
QC35ERCB	HV Amps	14.6	29.2	29.2	14.6	14.6	14.6	29.2	14.6	14.6	29.2	14.6	29.2	14.6	29.2	14.6
	KVA	5.26	10.50	11.00	5.78	6.12	6.31	12.10	6.45	6.67	10.50	6.04	11.55	10.54	22.05	11.60
	LV Amps	16.0	30.6	30.6	16.0	16.0	16.0	30.6	16.0	16.0	32.1	17.5	32.1	16.0	30.6	16.0
QC50ERCB	HV Amps	20.8	41.7	41.7	20.8	20.8	20.8	41.7	20.8	20.8	41.7	20.8	41.7	20.8	41.7	20.8
	KVA	7.51	15.00	15.80	8.26	8.74	9.02	17.30	9.21	9.53	15.0	8.60	16.5	15.1	31.5	16.5
	LV Amps	22.9	43.8	43.8	22.9	22.9	22.9	43.8	22.9	22.9	45.8	25.0	45.8	22.9	43.8	22.9
QC75ERCB	HV Amps	31.3	62.5	62.5	31.3	31.3	31.3	62.5	31.3	31.3	62.5	31.3	62.5	31.3	62.5	31.3
	KVA	11.3	22.5	23.7	12.4	13.1	13.5	25.9	13.8	14.3	22.5	12.9	24.8	22.6	47.3	24.8
	LV Amps	34.4	65.6	65.6	34.4	34.4	34.4	65.6	34.4	34.4	68.8	37.5	68.8	34.4	65.6	34.4
Q1C0ERCB	HV Amps	41.7	83.3	83.3	41.7	41.7	41.7	83.3	41.7	41.7	83.3	41.7	83.3	41.7	83.3	41.7
	KVA	15.0	30.0	31.5	16.5	17.5	18.0	34.6	18.4	19.1	30.0	17.3	33.0	30.1	63.0	33.0
	LV Amps	45.8	87.5	87.5	45.8	45.8	45.8	87.5	45.8	45.8	91.7	50.0	91.7	45.8	87.5	45.8
Q1C5ERCF	HV Amps	62.5	125.0	125.0	62.5	62.5	62.5	125.0	62.5	62.5	125	62.5	125	62.5	125.0	62.5
	KVA	22.5	45.0	47.3	24.8	26.2	27.0	51.8	27.6	28.6	45.0	25.9	49.5	45.2	94.5	49.5
	LV Amps	68.8	131.0	131.0	68.8	68.8	68.8	131.0	68.8	68.8	138	75.0	138	68.8	131	68.8
Q002ERCF	HV Amps	83.3	167.0	167.0	83.3	83.3	83.3	167.0	83.3	83.3	167	83.3	167	83.3	167.0	83.3
	KVA	30.0	60.0	63.1	33.0	34.9	36.1	69.1	36.8	38.1	60.0	34.5	66.0	60.3	126	66.0
	LV Amps	91.7	175.0	175.0	91.7	91.7	91.7	175.0	91.7	91.7	183	100	183	91.7	175	91.7
Q003ERCF	HV Amps	125	250	250	125	125	125	250	125	125	250	125	250	125	250	125
	KVA	45.0	90.0	94.6	49.5	52.4	54.1	103.7	55.3	57.2	90.0	51.8	99.0	90.4	189	99.0
	LV Amps	138	263	263	138	138	138	263	138	138	275	150	275	138	263	138
Q005ERCF	HV Amps	208	417	417	208	208	208	417	208	208	417	208	417	208	417	208
	KVA	75.0	150.0	157.6	82.6	87.3	90.1	172.8	92.1	95.3	150	86.3	165	151	315	165
	LV Amps	229	438	438	229	229	229	438	229	229	458	250	458	229	438	229

SELECTION CHARTS

THREE PHASE - GROUP B

1. From the top row of the "Selection Chart" locate the high and low voltage combination that is closest to the one you require.
2. Determine the quantity you required.
3. The corresponding connection diagram is indicated at the top of the Voltage / kVA column.
4. Move down that column to the kVA or Ampere rating equal to or greater than the rating required by the load.
5. From the far left column, obtain the transformer catalog number.
6. For dimensional information refer to the specifications table (Group A) on page 11.



120 X 240 PRIMARY VOLTS		16 X 32 SECONDARY VOLTS										50/60 HZ				
Catalog Number	Low Voltage	184	195	208	208	225	230	234	234	240	240	184	208	379	416	416
	High Voltage	209	208	222	236	240	245	250	265	272	256	106	120	219	240	240
QUANTITY REQUIRED		2	2	2	2	2	2	2	2	2	2	3	3	3	3	3
CONNECTION DIAGRAM		7	8	8	7	8	8	8	7	7	8	10	10	12	11	12
Three Phase Connection Style		Delta Connected										Wye Connected				
QC05ESCB	HV Amps	1.56	3.13	3.13	1.56	3.13	3.13	3.13	1.56	1.56	3.13	3.13	3.13	1.56	3.13	1.56
	KVA	0.57	1.13	1.21	0.64	1.30	1.33	1.36	0.72	0.74	1.39	1.13	1.28	1.17	2.40	1.28
QC10ESCB	HV Amps	1.77	3.33	3.33	1.77	3.33	3.33	3.33	1.77	1.77	3.33	3.54	3.54	1.77	3.33	1.77
	KVA	1.13	2.26	2.41	1.28	2.60	2.66	2.71	1.44	1.48	2.78	2.25	2.55	2.33	4.80	2.55
QC15ESCB	HV Amps	3.13	6.25	6.25	3.13	6.25	6.25	6.25	3.13	3.13	6.25	6.25	6.25	3.13	6.25	3.13
	KVA	1.70	3.38	3.61	1.92	3.90	3.99	4.06	2.16	2.21	4.16	3.38	3.83	3.50	7.20	3.83
QC20ESCB	HV Amps	5.31	10.00	10.00	5.31	10.00	10.00	10.00	5.31	5.31	10.00	10.6	10.6	5.31	10.0	5.31
	KVA	2.26	4.51	4.81	2.56	5.20	5.32	5.41	2.88	2.94	5.55	4.50	5.10	4.67	9.60	5.10
QC25ESCB	HV Amps	7.08	13.30	13.30	7.08	13.30	13.30	13.30	7.08	7.08	13.30	14.2	14.2	7.08	13.3	7.08
	KVA	2.83	5.63	6.01	3.19	6.50	6.64	6.76	3.59	3.69	6.93	5.63	6.38	5.84	12.0	6.38
QC35ESCB	HV Amps	8.85	16.70	16.70	8.90	16.70	16.70	16.70	8.85	8.85	16.70	17.7	17.7	8.85	16.7	8.85
	KVA	3.96	7.89	8.41	4.47	9.10	9.30	9.46	5.03	5.16	9.70	7.88	8.93	8.17	16.8	8.93
QC50ESCB	HV Amps	10.9	21.9	21.9	10.9	21.9	21.9	21.9	10.9	10.9	21.9	21.9	21.9	10.9	21.9	10.9
	KVA	12.4	23.3	23.3	12.4	23.3	23.3	23.3	12.4	12.4	23.3	24.8	24.8	12.4	23.3	12.4
QC75ESCB	HV Amps	15.6	31.3	31.3	15.6	31.3	31.3	31.3	15.6	15.6	31.3	31.3	31.3	15.6	31.3	15.6
	KVA	5.65	11.30	12.00	6.38	13.00	13.30	13.50	7.18	7.37	13.90	11.3	12.8	11.7	24.0	12.8
Q1C0ESCB	HV Amps	17.7	33.3	33.3	17.7	33.3	33.3	33.3	17.7	17.7	33.3	35.4	35.4	17.7	33.3	17.7
	KVA	23.4	46.9	46.9	23.4	46.9	46.9	46.9	23.4	23.4	46.9	46.9	46.9	23.4	46.9	23.4
Q1C5ESCF	HV Amps	8.47	16.90	18.00	9.57	19.5	19.9	20.3	10.8	11.1	20.8	16.9	19.1	17.5	36.0	19.1
	KVA	26.6	50.0	50.0	26.6	50.0	50.0	50.0	26.6	26.6	50.0	53.1	53.1	26.6	50.0	26.6
Q002ESCF	HV Amps	31.3	62.5	62.5	31.3	62.5	62.5	62.5	31.3	31.3	62.5	62.5	62.5	31.3	62.5	31.3
	KVA	11.3	22.5	24.0	12.8	26.0	26.6	27.0	14.4	14.7	27.7	22.5	25.5	23.3	48.0	25.5
Q003ESCF	HV Amps	35.4	66.7	66.7	35.4	66.7	66.7	66.7	35.4	35.4	66.7	70.8	70.8	35.4	66.7	35.4
	KVA	46.9	93.8	93.8	46.9	93.8	93.8	93.8	46.9	46.9	93.8	93.8	93.8	46.9	93.8	46.9
Q005ESCF	HV Amps	16.9	33.8	36.0	19.1	39.0	39.8	40.5	21.5	22.1	41.6	33.8	38.3	35.0	72.0	38.3
	KVA	53.1	100.0	100.0	53.1	100.0	100.0	100.0	53.1	53.1	100.0	106	106	53.1	100	53.1
Q005ESCF	HV Amps	62.5	125.0	125.0	62.5	125.0	125.0	125.0	62.5	62.5	125.0	125	125	62.5	125.0	62.5
	KVA	22.6	45.0	48.0	25.5	52.0	53.1	54.0	28.7	29.4	55.4	45.0	51.0	46.7	96.0	51.0
Q005ESCF	HV Amps	70.8	133.3	133.3	70.8	133.3	133.3	133.3	70.8	70.8	133.3	142	142	70.8	133	70.8
	KVA	93.75	187.5	187.5	93.75	187.5	187.5	187.5	93.75	93.75	187.5	188	188	93.8	188	93.8
Q005ESCF	HV Amps	33.9	67.6	72.1	38.3	78.0	79.7	81.1	43.1	44.2	83.1	67.5	76.5	70.0	144	76.5
	KVA	106.3	200	200	106.3	200	200	200	106.3	106.3	200	213	213	106	200	106
Q005ESCF	HV Amps	156.25	312.5	312.5	156.25	313	312.5	312.5	156.25	156.25	312.5	313	313	156	313	156
	KVA	56.4	112.6	120.1	63.8	129.9	132.8	135.1	71.8	73.6	138.6	113	128	117	240	128
Q005ESCF	HV Amps	177.1	333.3	333.3	177.1	333.3	333.3	333.3	177.1	177.1	333.3	354	354	177	333	177
	KVA															

SELECTION CHARTS

THREE PHASE - GROUP C

1. From the top row of the "Selection Chart" locate the high and low voltage combination that is closest to the one you require.
2. Determine the quantity you required.
3. The corresponding connection diagram is indicated at the top of the Voltage / kVA column.
4. Move down that column to the kVA or Ampere rating equal to or greater than the rating required by the load.
5. From the far left column, obtain the transformer catalog number.
6. For dimensional information refer to the specifications table (Group A) on page 11.



240 X 480 PRIMARY VOLTS		24 X 48 SECONDARY VOLTS										50/60 HZ				
Catalog Number	Low Voltage	173	200	208	362	380	400	419	436	457	480	480	346	379	400	416
	High Voltage	208	240	250	380	418	440	440	480	480	528	504	200	219	231	240
QUANTITY REQUIRED		2	2	2	2	2	2	2	2	2	2	2	3	3	3	3
CONNECTION DIAGRAM		5	5	5	6	7	7	8	7	8	7	8	9	9	9	9
Three Phase Connection Stle		Delta Connected										Wye Connected				
QC05DTCB	HV Amps	1.04	1.04	1.04	2.08	1.04	1.04	2.08	1.04	2.08	1.04	2.08	1.04	1.04	1.04	1.04
	KVA	0.38	0.44	0.46	1.44	0.76	0.8	1.67	0.87	1.82	0.96	1.82	0.75	0.82	0.87	0.9
	LV Amps	1.25	1.25	1.25	2.29	1.15	1.15	2.29	1.15	2.29	1.15	2.19	1.25	1.25	1.25	1.15
QC10DTCB	HV Amps	2.08	2.08	2.08	4.17	2.08	2.08	4.17	2.08	4.17	2.08	4.17	2.08	2.08	2.08	2.08
	KVA	0.75	0.87	0.91	2.88	1.51	1.59	3.33	1.74	3.63	1.91	3.64	1.5	1.64	1.73	1.8
	LV Amps	2.5	2.5	2.5	4.58	2.29	2.29	4.58	2.29	4.58	2.29	4.38	2.5	2.5	2.5	2.5
QC15DTCB	HV Amps	3.13	3.13	3.13	6.25	3.13	3.13	6.25	3.13	6.25	3.13	6.25	3.13	3.13	3.13	3.13
	KVA	1.13	1.3	1.36	4.32	2.27	2.39	4.99	2.6	5.45	2.86	5.46	2.25	2.47	2.6	2.7
	LV Amps	3.75	3.75	3.75	6.88	3.44	3.44	6.88	3.44	6.88	3.44	6.56	3.75	3.75	3.75	3.75
QC20DTCB	HV Amps	4.17	4.17	4.17	8.33	4.17	4.17	8.33	4.17	8.33	4.17	8.33	4.17	4.17	4.17	4.17
	KVA	1.5	1.74	1.81	5.75	3.02	3.18	6.66	3.47	7.26	3.82	7.28	3	3.29	3.46	3.6
	LV Amps	5	5	5	9.17	4.58	4.58	9.17	4.58	9.17	4.58	8.75	5	5	5	5
QC25DTCB	HV Amps	5.21	5.21	5.21	10.4	5.21	5.21	10.4	5.21	10.4	5.21	10.4	5.21	5.21	5.21	5.21
	KVA	1.88	2.17	2.26	7.19	3.78	3.97	8.32	4.33	9.07	4.77	9.1	3.75	4.11	4.33	4.5
	LV Amps	6.25	6.25	6.25	11.5	5.73	5.73	11.5	5.73	11.5	5.73	10.9	6.25	6.25	6.25	6.25
QC35DTCB	HV Amps	7.29	7.29	7.29	14.6	7.29	7.3	14.6	7.3	14.6	7.29	14.6	7.29	7.29	7.29	7.29
	KVA	2.63	3.04	3.16	10.1	5.28	5.56	11.7	6.06	12.7	6.67	12.7	5.25	5.75	6.06	6.3
	LV Amps	8.75	8.75	8.75	16	8	8	16	8	16	8.02	15.3	8.75	8.75	8.75	8.75
QC50DTCB	HV Amps	10.4	10.4	10.4	20.8	10.4	10.4	20.8	10.4	20.8	10.4	20.8	10.4	10.4	10.4	10.4
	KVA	3.75	4.34	4.51	14.4	7.55	7.94	16.6	8.66	18.1	9.53	18.2	7.5	8.22	8.66	9
	LV Amps	12.5	12.5	12.5	22.9	11.5	11.5	22.9	11.5	22.9	11.5	21.9	12.5	12.5	12.5	12.5
QC75DTCB	HV Amps	15.6	15.6	15.6	31.3	15.6	15.6	31.3	15.6	31.3	15.6	31.3	15.6	15.6	15.6	15.6
	KVA	5.62	6.5	6.76	21.6	11.3	11.9	25	13	27.2	14.3	27.3	11.3	12.3	13	13.5
	LV Amps	18.8	18.8	18.8	34.4	17.2	17.2	34.4	17.2	34.4	17.2	32.8	18.8	18.8	18.8	18.8
Q1C0DTCB	HV Amps	20.8	20.8	20.8	41.7	20.8	20.8	41.7	20.8	41.7	20.8	41.7	20.8	20.8	20.8	20.8
	KVA	7.5	8.67	9.01	28.7	15.1	15.9	33.3	17.3	36.3	19.1	36.4	15	16.4	17.3	18
	LV Amps	25	25	25	45.8	22.9	22.9	45.8	22.9	45.8	22.9	43.8	25	25	25	25
Q1C5DTCF	HV Amps	31.3	31.3	31.3	62.5	31.3	31.3	62.5	31.3	62.5	31.3	62.5	31.3	31.3	31.3	31.3
	KVA	11.2	13	13.5	43.1	22.6	23.8	49.9	26	54.4	28.6	54.6	22.5	24.7	26	27
	LV Amps	37.5	37.5	37.5	68.8	34.4	34.4	68.8	34.4	68.8	34.4	65.6	37.5	37.5	37.5	37.5
Q002DTCF	HV Amps	41.7	41.7	41.7	83.3	41.7	41.7	83.3	41.7	83.8	41.7	83.3	41.7	41.7	41.7	41.7
	KVA	15	17.3	18	57.5	30.2	31.8	66.5	34.6	72.6	38.1	72.8	30	32.9	34.6	36
	LV Amps	50	50	50	91.7	45.8	45.8	91.7	45.8	91.7	45.8	87.5	50	50	50	50
Q003DTCF	HV Amps	62.5	62.5	62.5	125	62.5	62.5	125	62.5	125	62.5	125	62.5	62.5	62.5	62.5
	KVA	22.5	26	27	86.2	45.3	47.6	99.8	51.9	109	57.2	109	45	49.3	51.9	54
	LV Amps	75	75	75	138	68.8	68.8	138	68.8	138	68.8	131	75	75	75	75
Q005DTCF	HV Amps	104	104	104	208	104	104	208	104	208	104	208	104	104	104	104
	KVA	37.5	43.3	45	144	75.4	79.4	166	86.5	181	95.3	182	75	82.2	86.6	90
	LV Amps	125	125	125	229	115	115	229	115	229	115	219	125	125	125	125

SINGLE PHASE SPECIFICATION TABLES

Group A



120 X 240 PRIMARY VOLTS

12 X 24 SECONDARY VOLTS

50/60 HZ

VA	Catalog Number	Case Style	Approx. Dimensions Inches [mm]			Approx. Weight Lbs. [kg]	Mtg Type W - Wall
			Width	Depth	Height		
50	QC05ERCB	NQ0	3.69 [93.73]	5.06 [128.53]	7.19 [182.63]	6 [2.7]	W
100	QC10ERCB	NQ0	3.69 [93.73]	5.06 [128.53]	7.19 [182.63]	7 [3.2]	W
150	QC15ERCB	NQ0	3.69 [93.73]	5.06 [128.53]	7.19 [182.63]	8 [3.6]	W
200	QC20ERCB	NQ1	4.31 [109.48]	5.56 [141.23]	7.19 [182.63]	11 [5.0]	W
250	QC25ERCB	NQ1	4.31 [109.48]	5.56 [141.23]	7.19 [182.63]	13 [5.9]	W
350	QC35ERCB	NQ1	4.31 [109.48]	5.56 [141.23]	7.19 [182.63]	14 [6.3]	W
500	QC50ERCB	NQ2	5.06 [128.53]	4.56 [115.83]	9.30 [236.22]	15 [6.8]	W
750	QC75ERCB	NQ2	5.06 [128.53]	4.56 [115.83]	9.30 [236.22]	18 [8.1]	W
1000	Q1C0ERCB	NQ3	5.88 [149.36]	5.19 [131.83]	10.56 [268.23]	25 [11.3]	W
1500	Q1C5ERCF	NQ4	7.06 [179.33]	6.25 [158.75]	11.75 [298.45]	36 [16.2]	W
2000	Q002ERCF	NQ4	7.06 [179.33]	6.25 [158.75]	11.75 [298.45]	46 [20.7]	W
3000	Q003ERCF	NQ5	10.00 [254.00]	7.75 [196.85]	17.25 [438.15]	65 [29.3]	W
5000	Q005ERCF	NQ5	10.00 [254.00]	7.75 [196.85]	17.25 [438.15]	105 [47.3]	W

Group B

120 X 240 PRIMARY VOLTS

16 X 32 SECONDARY VOLTS

50/60 HZ

VA	Catalog Number	Case Style	Approx. Dimensions Inches [mm]			Approx. Weight Lbs. [kg]	Mtg Type W - Wall
			Width	Depth	Height		
50	QC05ESCB	NQ0	3.69 [93.73]	5.06 [128.53]	7.19 [182.63]	6 [2.7]	W
100	QC10ESCB	NQ0	3.69 [93.73]	5.06 [128.53]	7.19 [182.63]	7 [3.2]	W
150	QC15ESCB	NQ0	3.69 [93.73]	5.06 [128.53]	7.19 [182.63]	8 [3.6]	W
200	QC20ESCB	NQ1	4.31 [109.48]	5.56 [141.23]	7.19 [182.63]	11 [5.0]	W
250	QC25ESCB	NQ1	4.31 [109.48]	5.56 [141.23]	7.19 [182.63]	13 [5.9]	W
350	QC35ESCB	NQ1	4.31 [109.48]	5.56 [141.23]	7.19 [182.63]	14 [6.3]	W
500	QC50ESCB	NQ2	5.06 [128.53]	4.56 [115.83]	9.30 [236.22]	15 [6.8]	W
750	QC75ESCB	NQ2	5.06 [128.53]	4.56 [115.83]	9.30 [236.22]	18 [8.1]	W
1000	Q1C0ESCB	NQ3	5.88 [149.36]	5.19 [131.83]	10.56 [268.23]	25 [11.3]	W
1500	Q1C5ESCF	NQ4	7.06 [179.33]	6.25 [158.75]	11.75 [298.45]	36 [16.2]	W
2000	Q002ESCF	NQ4	7.06 [179.33]	6.25 [158.75]	11.75 [298.45]	46 [20.7]	W
3000	Q003ESCF	NQ5	10.00 [254.00]	7.75 [196.85]	17.25 [438.15]	65 [29.3]	W
5000	Q005ESCF	NQ5	10.00 [254.00]	7.75 [196.85]	17.25 [438.15]	105 [47.3]	W

Group C

240 X 480 PRIMARY VOLTS

24 X 48 SECONDARY VOLTS

50/60 HZ

VA	Catalog Number	Case Style	Approx. Dimensions Inches [mm]			Approx. Weight Lbs. [kg]	Mtg Type W - Wall
			Width	Depth	Height		
50	QC05DTCB	NQ0	3.69 [93.73]	5.06 [128.53]	7.19 [182.63]	6 [2.7]	W
100	QC10DTCB	NQ0	3.69 [93.73]	5.06 [128.53]	7.19 [182.63]	7 [3.2]	W
150	QC15DTCB	NQ0	3.69 [93.73]	5.06 [128.53]	7.19 [182.63]	8 [3.6]	W
200	QC20DTCB	NQ1	4.31 [109.48]	5.56 [141.23]	7.19 [182.63]	11 [5.0]	W
250	QC25DTCB	NQ1	4.31 [109.48]	5.56 [141.23]	7.19 [182.63]	13 [5.9]	W
350	QC35DTCB	NQ1	4.31 [109.48]	5.56 [141.23]	7.19 [182.63]	14 [6.3]	W
500	QC50DTCB	NQ2	5.06 [128.53]	4.56 [115.83]	9.30 [236.22]	15 [6.8]	W
750	QC75DTCB	NQ2	5.06 [128.53]	4.56 [115.83]	9.30 [236.22]	18 [8.1]	W
1000	Q1C0DTCB	NQ3	5.88 [149.36]	5.19 [131.83]	10.56 [268.23]	25 [11.3]	W
1500	Q1C5DTCF	NQ4	7.06 [179.33]	6.25 [158.75]	11.75 [298.45]	36 [16.2]	W
2000	Q002DTCF	NQ4	7.06 [179.33]	6.25 [158.75]	11.75 [298.45]	46 [20.7]	W
3000	Q003DTCF	NQ5	10.00 [254.00]	7.75 [196.85]	17.25 [438.15]	65 [29.3]	W
5000	Q005DTCF	NQ5	10.00 [254.00]	7.75 [196.85]	17.25 [438.15]	105 [47.3]	W

THREE PHASE SPECIFICATION TABLES

Group A



120 X 240 PRIMARY VOLTS

12 X 24 SECONDARY VOLTS

50/60 HZ

VA	Catalog Number	Case Style	Approx. Dimensions Inches [mm]			Approx. Weight Lbs. [kg]	Mtg Type W - Wall
			Width	Depth	Height		
50	QC05ERCB	NQ0	3.69 [93.73]	5.06 [128.53]	7.19 [182.63]	6 [2.7]	W
100	QC10ERCB	NQ0	3.69 [93.73]	5.06 [128.53]	7.19 [182.63]	7 [3.2]	W
150	QC15ERCB	NQ0	3.69 [93.73]	5.06 [128.53]	7.19 [182.63]	8 [3.6]	W
200	QC20ERCB	NQ1	4.31 [109.48]	5.56 [141.23]	7.19 [182.63]	11 [5.0]	W
250	QC25ERCB	NQ1	4.31 [109.48]	5.56 [141.23]	7.19 [182.63]	13 [5.9]	W
350	QC35ERCB	NQ1	4.31 [109.48]	5.56 [141.23]	7.19 [182.63]	14 [6.3]	W
500	QC50ERCB	NQ2	5.06 [128.53]	4.56 [115.83]	9.30 [236.22]	15 [6.8]	W
750	QC75ERCB	NQ2	5.06 [128.53]	4.56 [115.83]	9.30 [236.22]	18 [8.1]	W
1000	Q1C0ERCB	NQ3	5.88 [149.36]	5.19 [131.83]	10.56 [268.23]	25 [11.3]	W
1500	Q1C5ERCF	NQ4	7.06 [179.33]	6.25 [158.75]	11.75 [298.45]	36 [16.2]	W
2000	Q002ERCF	NQ4	7.06 [179.33]	6.25 [158.75]	11.75 [298.45]	46 [20.7]	W
3000	Q003ERCF	NQ5	10.00 [254.00]	7.75 [196.85]	17.25 [438.15]	65 [29.3]	W
5000	Q005ERCF	NQ5	10.00 [254.00]	7.75 [196.85]	17.25 [438.15]	105 [47.3]	W

Group B

120 X 240 PRIMARY VOLTS

16 X 32 SECONDARY VOLTS

50/60 HZ

VA	Catalog Number	Case Style	Approx. Dimensions Inches [mm]			Approx. Weight Lbs. [kg]	Mtg Type W - Wall
			Width	Depth	Height		
50	QC05ESCB	NQ0	3.69 [93.73]	5.06 [128.53]	7.19 [182.63]	6 [2.7]	W
100	QC10ESCB	NQ0	3.69 [93.73]	5.06 [128.53]	7.19 [182.63]	7 [3.2]	W
150	QC15ESCB	NQ0	3.69 [93.73]	5.06 [128.53]	7.19 [182.63]	8 [3.6]	W
200	QC20ESCB	NQ1	4.31 [109.48]	5.56 [141.23]	7.19 [182.63]	11 [5.0]	W
250	QC25ESCB	NQ1	4.31 [109.48]	5.56 [141.23]	7.19 [182.63]	13 [5.9]	W
350	QC35ESCB	NQ1	4.31 [109.48]	5.56 [141.23]	7.19 [182.63]	14 [6.3]	W
500	QC50ESCB	NQ2	5.06 [128.53]	4.56 [115.83]	9.30 [236.22]	15 [6.8]	W
750	QC75ESCB	NQ2	5.06 [128.53]	4.56 [115.83]	9.30 [236.22]	18 [8.1]	W
1000	Q1C0ESCB	NQ3	5.88 [149.36]	5.19 [131.83]	10.56 [268.23]	25 [11.3]	W
1500	Q1C5ESCF	NQ4	7.06 [179.33]	6.25 [158.75]	11.75 [298.45]	36 [16.2]	W
2000	Q002ESCF	NQ4	7.06 [179.33]	6.25 [158.75]	11.75 [298.45]	46 [20.7]	W
3000	Q003ESCF	NQ5	10.00 [254.00]	7.75 [196.85]	17.25 [438.15]	65 [29.3]	W
5000	Q005ESCF	NQ5	10.00 [254.00]	7.75 [196.85]	17.25 [438.15]	105 [47.3]	W

Group C

240 X 480 PRIMARY VOLTS

24 X 48 SECONDARY VOLTS

50/60 HZ

VA	Catalog Number	Case Style	Approx. Dimensions Inches [mm]			Approx. Weight Lbs. [kg]	Mtg Type W - Wall
			Width	Depth	Height		
50	QC05DTCB	NQ0	3.69 [93.73]	5.06 [128.53]	7.19 [182.63]	6 [2.7]	W
100	QC10DTCB	NQ0	3.69 [93.73]	5.06 [128.53]	7.19 [182.63]	7 [3.2]	W
150	QC15DTCB	NQ0	3.69 [93.73]	5.06 [128.53]	7.19 [182.63]	8 [3.6]	W
200	QC20DTCB	NQ1	4.31 [109.48]	5.56 [141.23]	7.19 [182.63]	11 [5.0]	W
250	QC25DTCB	NQ1	4.31 [109.48]	5.56 [141.23]	7.19 [182.63]	13 [5.9]	W
350	QC35DTCB	NQ1	4.31 [109.48]	5.56 [141.23]	7.19 [182.63]	14 [6.3]	W
500	QC50DTCB	NQ2	5.06 [128.53]	4.56 [115.83]	9.30 [236.22]	15 [6.8]	W
750	QC75DTCB	NQ2	5.06 [128.53]	4.56 [115.83]	9.30 [236.22]	18 [8.1]	W
1000	Q1C0DTCB	NQ3	5.88 [149.36]	5.19 [131.83]	10.56 [268.23]	25 [11.3]	W
1500	Q1C5DTCF	NQ4	7.06 [179.33]	6.25 [158.75]	11.75 [298.45]	36 [16.2]	W
2000	Q002DTCF	NQ4	7.06 [179.33]	6.25 [158.75]	11.75 [298.45]	46 [20.7]	W
3000	Q003DTCF	NQ5	10.00 [254.00]	7.75 [196.85]	17.25 [438.15]	65 [29.3]	W
5000	Q005DTCF	NQ5	10.00 [254.00]	7.75 [196.85]	17.25 [438.15]	105 [47.3]	W

SINGLE PHASE CONNECTION DIAGRAMS

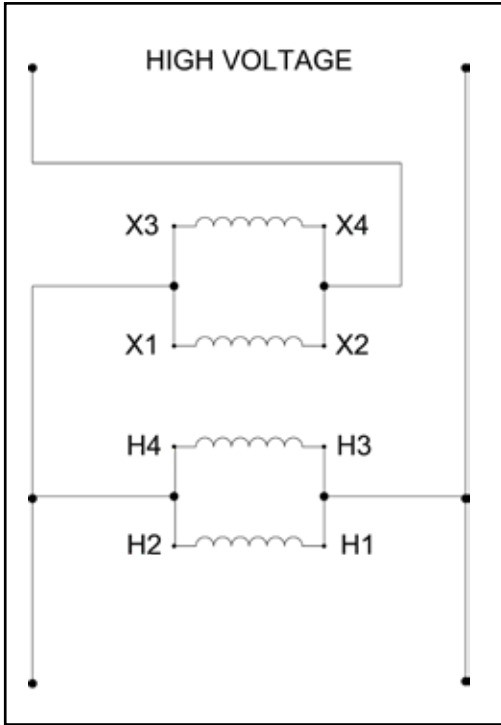

Connection Diagram #1

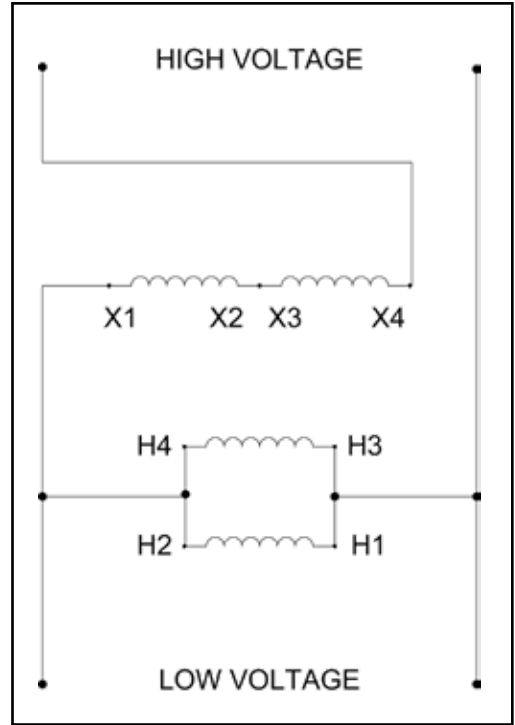

Connection Diagram #2

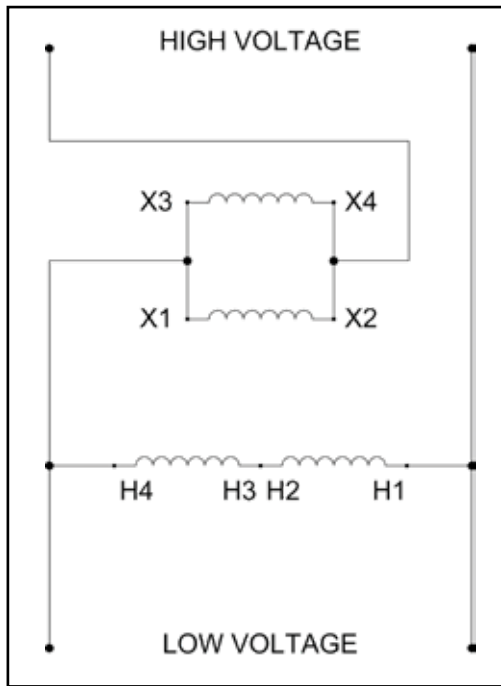

Connection Diagram #3

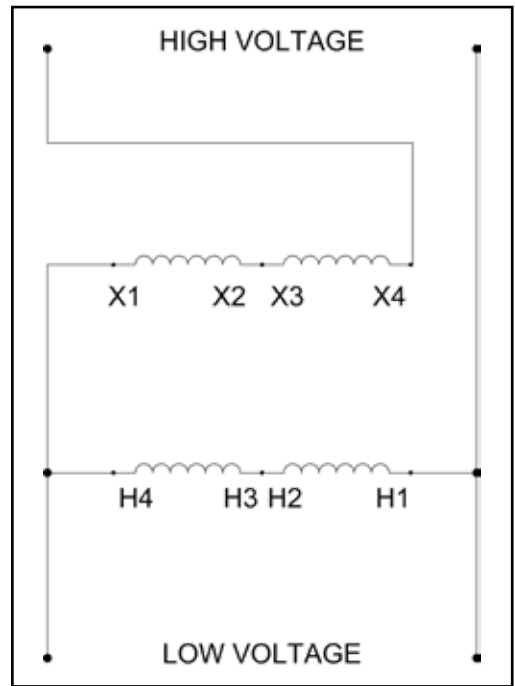

Connection Diagram #4

THREE PHASE CONNECTION DIAGRAMS

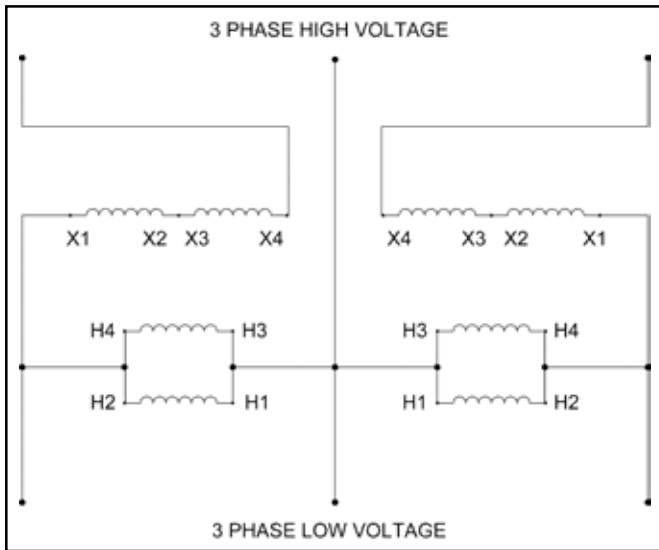

Connection Diagram #5

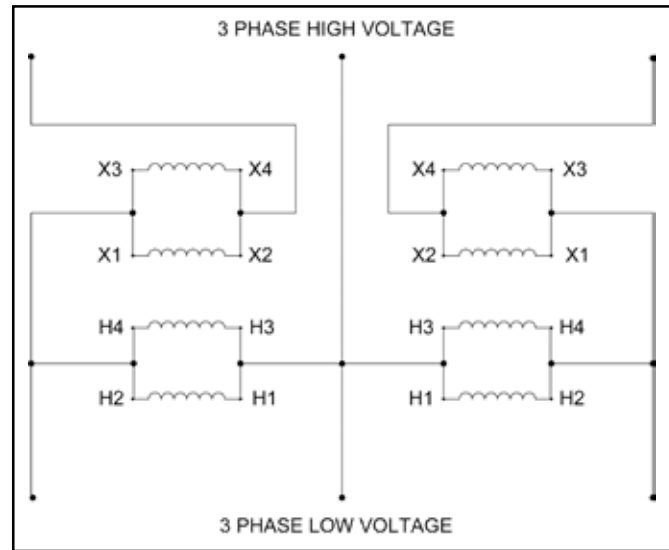

Connection Diagram #6

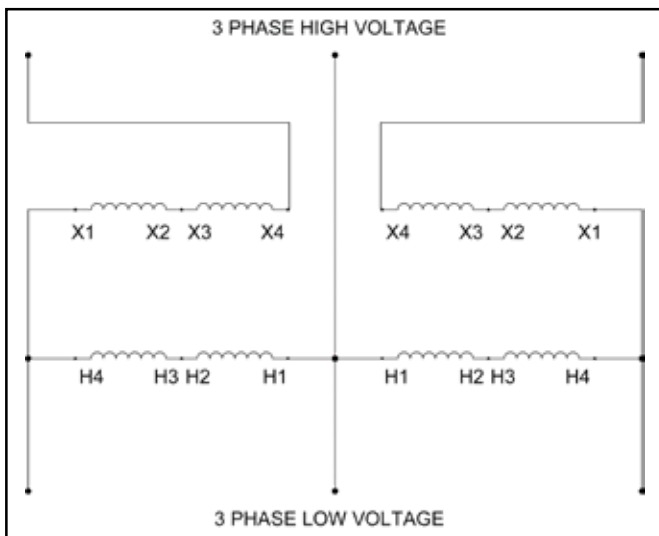

Connection Diagram #7

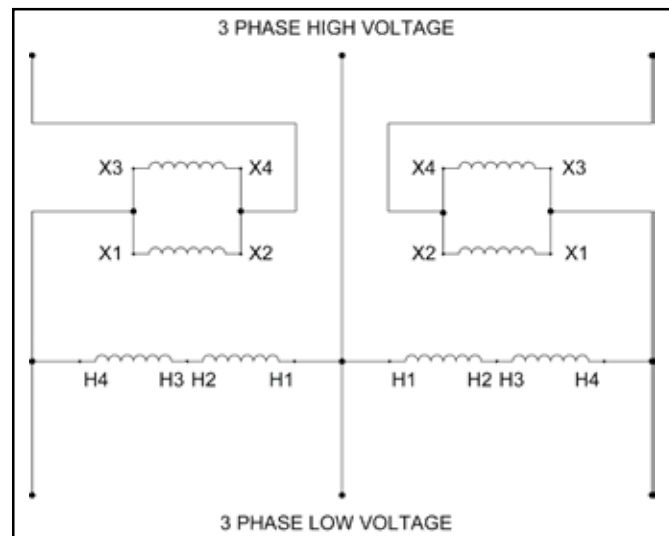

Connection Diagram #8

THREE PHASE CONNECTION DIAGRAMS

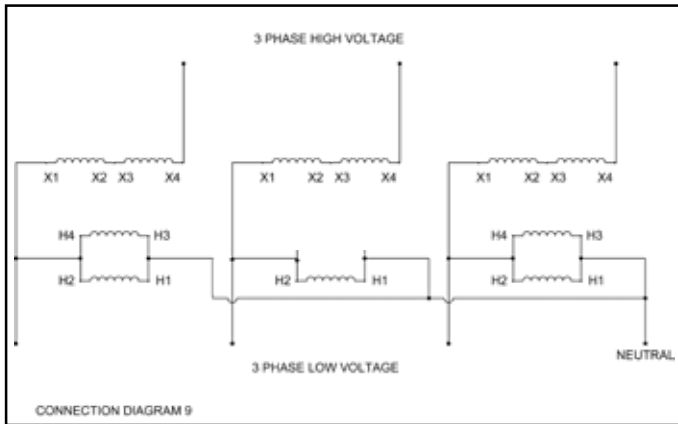

Connection Diagram #9

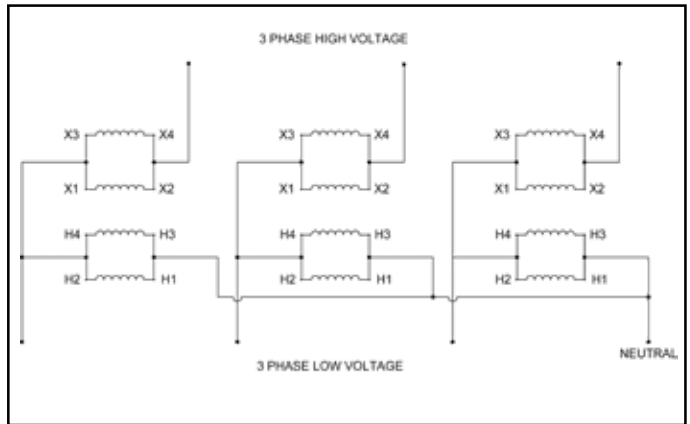

Connection Diagram #10

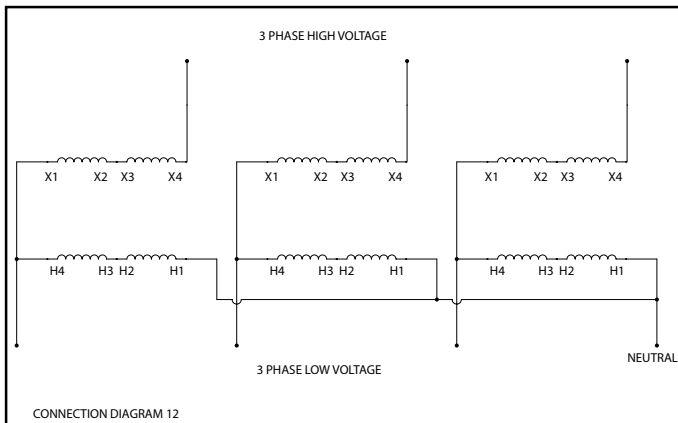

Connection Diagram #11

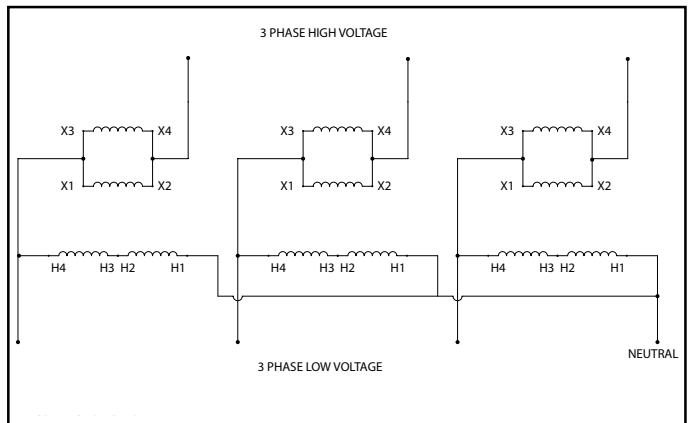

Connection Diagram #12

TYPE 3R ENCLOSURE DIMENSIONAL DRAWINGS

'NQ' Series Enclosures

Figure 1

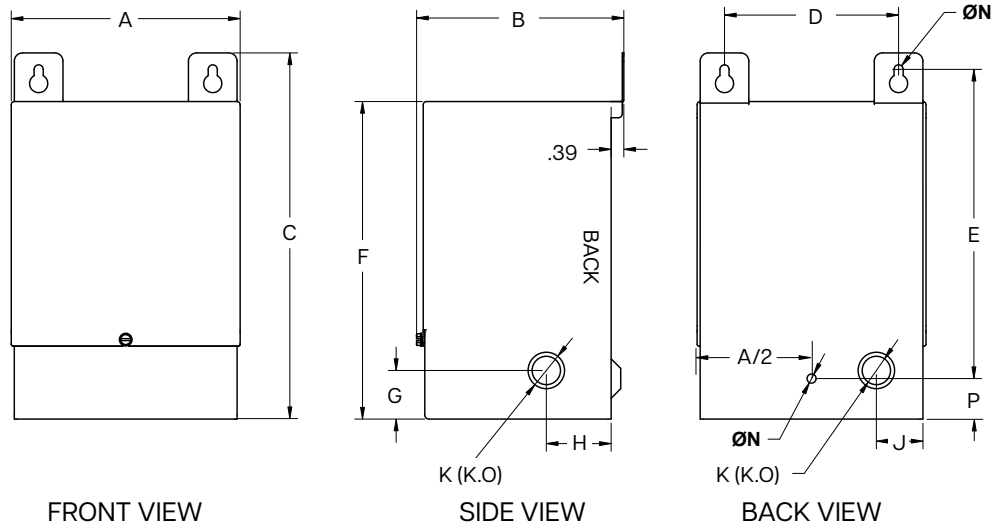

Case Style	Fig #	Dimensions in Inches [mm]														
		A	B	C	D	E	F	G	H	J	K'	L	M	N	P	R
NQ0	1	3.69 [93.73]	5.06 [128.53]	7.19 [182.63]	2.50 [63.50]	5.63 [143.01]	6.19 [157.23]	1.50 [38.10]	2.00 [50.80]	--	0.88 [22.36]	--	--	0.22 [5.59]	1.25 [31.75]	--
NQ1	1	4.31 [109.48]	5.56 [141.23]	7.19 [182.63]	3.13 [79.51]	5.63 [143.01]	6.13 [155.71]	1.50 [38.10]	2.00 [50.80]	0.81 [20.58]	0.88 [22.36]	--	--	0.22 [5.59]	1.25 [31.75]	--
NQ2	1	5.06 [128.53]	4.56 [115.83]	9.30 [236.22]	3.88 [98.56]	7.75 [196.85]	8.30 [210.82]	1.50 [38.10]	2.00 [50.80]	1.00 [25.40]	88 X 1.13 X 1.38 [22.36 X 28.71 X 35.06]	--	--	0.22 [5.59]	1.25 [31.75]	--
NQ3	1	5.88 [149.36]	5.19 [131.83]	10.56 [268.23]	4.13 [104.91]	8.31 [211.08]	9.06 [230.13]	1.50 [38.10]	2.00 [50.80]	1.25 [31.75]	0.88 X 1.13 X 1.38 [22.36 X 28.71 X 35.06]	--	--	0.28 [7.12]	1.25 [31.75]	--
NQ4	1	7.06 [179.33]	6.25 [158.75]	11.75 [298.45]	5.38 [136.66]	10.00 [254.00]	10.30 [261.62]	1.75 [44.45]	2.00 [50.80]	1.50 [38.10]	0.88 X 1.13 X 1.38 [22.36 X 28.71 X 35.06]	--	--	0.28 [7.12]	1.25 [31.75]	--
NQ5	2	10.00 [254.00]	7.75 [196.85]	17.25 [438.15]	7.38 [187.46]	15.38 [390.66]	15.25 [387.35]	2.38 [60.33]	2.00 [50.80]	4.00 [101.60]	1.13 X 1.38 [28.71 X 35.06]	6.00 [152.40]	0.75 [19.05]	0.44 [11.18]	1.25 [31.75]	1.68 [42.68]

*Knockout (K) sizes are actual diameters of knockout, not conduit sizes. Refer to table on page 16 for conduit sizes.

Optional Stainless Steel Enclosures are available.

Figure 2

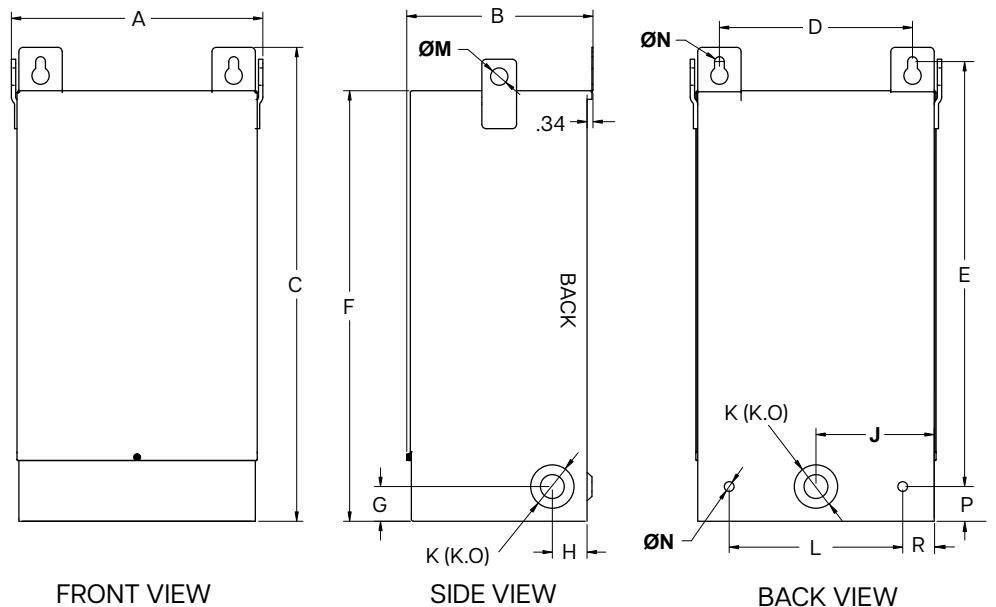

Conduit Size vs. Actual Knockout Size Reference Tables

Standard Conduit Size*	Actual Knockout Diameter*
1/2" [12.7]	7/8" [22.22]
3/4" [19.05]	1 1/8" [28.57]
1" [25.4]	1 3/8" [34.925]
1 1/4" [31.75]	1 3/4" [44.45]
1 1/2" [38.1]	2" [50.8]
2" [50.8]	2 1/2" [63.5]
2 1/2" [63.5]	3" [76.2]
3" [76.2]	3 5/8" [92.07]
3 1/2" [88.9]	4 1/8" [4.125]

**Dimensions in Inches [mm]*

1. What is a buck-boost transformer?

Buck-boost transformers are small single phase transformers designed to lower (buck) or raise (boost) line voltage from 5-20%. The most common applications for buck-boost transformers include boosting 208 volts to 230 or 240 volts for air conditioning systems, boosting 110 to 120 volts and 240 to 277 volts for lighting applications, heating systems and induction motors of all types. Many applications exist where supply voltages are frequently above or below nominal.

Buck-boost transformers are conventional low voltage, single phase distribution transformers, with standard primary voltages of 120, 240 or 480 volts, and secondary voltages of 12, 16, 24, 32 or 48 volts. They are available in sizes ranging from 50 VA to 10,000 VA. The primary and secondary are wired together to form a single-winding autotransformer. Utilizing the additive and subtractive polarity, small amounts of voltage are either added or subtracted from a distribution circuit.

2. How does a buck-boost transformer differ from an isolating transformer?

A buck-boost transformer is manufactured as an isolating transformer, with separable primary and secondary, and is shipped from the factory in that configuration. When the end user at site connects it, the primary is connected to the secondary changing the transformer's electrical characteristics to those of an autotransformer. This provides the smaller voltage correction that is typical of buck-boost. The primary and secondary windings are no longer isolated as they are connected together.

3. What is the difference between a buck-boost transformer and an autotransformer?

As noted above, when the primary and secondary are connected together to buck or boost voltage, the transformer becomes an autotransformer. If the connection between the primary and secondary winding is not made, then the unit remains as an isolation transformer.

Applications

4. Why are they used?

A buck-boost transformer is a simple and effective way of correcting off-standard voltages. Electrical and electronic equipment is designed to operate within a standard tolerance of nominal supply voltages. When the supply voltage is consistently too high or low - typically more than 10%, the equipment will operate below peak efficiency.

5. Can buck-boost transformers be used to power low voltage circuits?

Installed as two-winding, isolation transformers, these units can be used to power low voltage circuits including control, lighting circuits, or other low voltage applications that require 12, 16, 24, 32 or 48 volts output, consistent with the secondary of these designs. The unit is connected as an isolating transformer and the nameplate kVA rating is the transformer's capacity.

Operation and Construction

6. Why do buck-boost transformers have 4 windings?

A four winding buck-boost transformer with 2 primary and 2 secondary windings can be connected eight different ways to provide a multitude of voltages and KVA's. This provides the flexibility necessary for the broad variety of applications. A two-winding transformer can only be connected in two different ways.

7. Will a Buck-Boost transformer stabilize voltage?

Buck-boost transformers will not stabilize supply line voltage. The output voltage of a buck-boost is a function of the input voltage. If the input voltage varies, then the output voltage will also vary by the same percentage.

Load Data

8. Are there any restrictions on the type of load that can be operated from a Buck-Boost transformer?

There are no restrictions as to application for Buck-Boost, including single or three-phase motor loads.

QUESTIONS & ANSWERS

9. As an Autotransformer, how can a Buck-Boost transformer supply kVA power?

This is a function of adding voltage - a small amount of voltage is added and a small amount of corresponding power capacity is added as well. For example, if the transformer is connected in such a way that 22 volts is added to a 208 volt primary, a 230 volt output will result.

Using this example, the calculation for autotransformer kVA is as follows:

$$\frac{\text{Output Volts} \times \text{Secondary Amps}}{1000}$$
$$\frac{230\text{V} \times 41.67 \text{ Amps}}{1000} = 9.58 \text{ KVA}$$

10. How are single phase and three phase load amps and load kVA calculated?

$$\frac{\text{kVA} \times 1000}{\text{Volts}}$$
$$\frac{\text{Volts} \times \text{Amps}}{1000}$$
$$\text{Three phase Amps} = \frac{\text{kVA} \times 1000}{\text{Volts} \times 1.73}$$
$$\text{Three phase kVA} = \frac{\text{Volts} \times \text{Amps} \times 1.73}{1000}$$

Three Phase

11. Can Buck-Boost transformers be used on three phase systems?

Interconnecting two or three single phase units will readily accommodate three phase systems - refer to the corresponding three phase section in this catalog. The number of units to be used in a three phase installation depends on the number of wires in the supply line. If the three phase supply is 4-wire wye, then three buck-boost transformers are required. If the three phase supply is 3-wire wye (neutral not available), two buck-boost transformers are needed.

12. Should Buck-Boost transformers be used to develop three phase 4 wire wye circuits from three phase 3 wire delta circuits?

No - a three-phase "wye" buck-boost transformer connection should be used only on a 4-wire source of supply. A delta to wye connection does not provide adequate current capacity to accommodate unbalanced currents flowing in the neutral wire of the 4-wire circuit.

13. Why isn't a 'closed delta' Buck-Boost connection recommended?

This connection requires more kVA power than a "wye" or open delta connection and phase shifting occurs on the output. The closed delta connection is more expensive and electrically inferior to other three phase connections.

Connection and Frequency

14. How do you know how to connect a Buck-Boost transformer?

A connection chart is provided with each unit that shows how to make the corresponding connections. These same charts are also shown in this section.

15. Can 60 Hertz Buck-Boost transformers be operated on 50 Hertz?

Due to 'saturation' of the core, 60 Hertz buck-boost transformers should only be operated at 60 Hertz, and not 50 Hertz. Units manufactured as 50 Hertz units will however, operate at 60 Hertz.

Nameplate Data

17. Why are buck-boost transformers shipped from the factory connected as isolating transformers, and not pre-connected autotransformers?

The same 4-winding buck-boost transformer can be connected eight different ways to provide a multitude of voltage combinations. The correct connection can best be determined by the user when assessing the supply voltage at site.

18. Why is the isolation transformer kVA rating shown on the nameplate instead of the autotransformer kVA rating?

Shipped as an isolating transformer, the nameplate is required to show the performance characteristics accordingly. Additionally, as an autotransformer, the eight different combinations of voltages and kVA's would be impractical to list on the nameplate. A connection chart, listing the various connections, is included with each unit.

Sound Levels

19. How does the sound level differ between Buck-Boost and isolation transformers?

Buck-boost transformers, connected as autotransformers, will be quieter than an equivalent isolation transformer capable of handling the same load. The isolation transformer would have to be physically larger than the buck-boost transformer, and smaller transformers are quieter than larger ones. For example, a 10 kVA is 35 dba and a 75 kVA is 50 dba.

Cost and Life Expectancy

20. How does the costs compare between a Buck-Boost transformer and an Isolation transformer handling the same load?

For most buck-boost applications, the savings are about 75% compared to the use of an isolation transformer for the same application.

21. What is the life expectancy of a Buck-Boost transformer?

Buck-boost transformers have exactly the same life expectancy as other dry-type transformers.

22. Buck-Boost transformers are almost always installed as autotransformers. Does the National Electrical Code (NEC) permit the use of autotransformers?

Autotransformers are very common and recognized by all the safety and standard authorities. You can refer to N.E.C. Article 450-4, "Autotransformers 600 Volts, Nominal, or Less", as a reference publication. Item (a) details overcurrent protection for an autotransformer and item (b) covers an isolation transformer being field connected as an autotransformer for a buck-boost application.

23. When a Buck-Boost transformer is connected as an autotransformer, what is the procedure for determining the current rating of the overcurrent protective device, such as the fuse or circuit breaker?

The NEC Article 450-4 outlines overcurrent protection for autotransformers. It is reproduced as follows:
"NEC 450-4 - Autotransformers 600 Volts, Nominal, or Less

(a) Overcurrent Protection. Each autotransformer 600 volts, nominal, or less shall be protected by an individual overcurrent device installed in series with each ungrounded input conductor. Such overcurrent device shall be rated or set at not more than 125 percent of the rated full load input current of the autotransformer. An overcurrent device shall not be installed in series with the shunt winding.

Exception: Where the rated input current of an autotransformer is 9 amperes or more and 125 percent of this current does not correspond to a standard rating of a fuse or non-adjustable circuit breaker; the next higher standard rating described in our section shall be permitted. When the rated input current is less than 9 amperes, an overcurrent device rated or set at not more than 167 percent of the input current shall be permitted.

(b) Transformer Field-Connected as an autotransformer. A transformer field-connected as autotransformers shall be identified for use at "elevated voltage".

Example: A 1 kVA transformer, Catalog No. Q1C0ERCB, is rated 120 x 240 to 12 x 24 volts. It is to be connected as an autotransformer to raise 208 to 230 volts single phase. When connected as an autotransformer in this application, the kVA rating is increased to 9.58 kVA, or 9,580 VA. This is the rating to be used for determining the full load input amps and the corresponding size of the overcurrent protection device, either a fuse or breaker.

$$\text{Full load input amps} = 9,580 \text{ Volt Amps} = 46 \text{ Amp, } 208 \text{ Volts}$$

When the full load current is greater than 9 amps, the overcurrent protection device - usually a fuse or non-adjustable breaker, the current rating can be up to 125 percent of the full load rating of the autotransformer input current.

$$\text{Max. current rating of the overcurrent device} = 46 \text{ amps} \times 125\% = 57.5 \text{ amps}$$

The National Electrical Code, Article 450-4 (a) Exception, permits the use of the next higher standard ampere rating of the overcurrent device. This is shown in Article 240-6 of the N.E.C.

$$\text{Max. size of the fuse or circuit breaker} = 60 \text{ amps}$$



CANADA

Hammond Power Solutions

595 Southgate Drive
Guelph, Ontario N1G 3W6
Tel: (519) 822-2441 | Fax: (519) 822-9701
Toll Free: 1-888-798-8882

sales@hammondpowersolutions.com



UNITED STATES

Hammond Power Solutions

1100 Lake Street
Baraboo, Wisconsin 53913-2866
Tel: (608) 356-3921 | Fax: (608) 355-7623
Toll Free: 1-866-705-4684

sales@hammondpowersolutions.com



MEXICO

Hammond Power Solutions Latin America S.

Av. No. 800,
Parque Industrial Guadalupe
Guadalupe, NL, Mexico, C.P. 67190.
Tel: (819) 690-8000

sales@hammondpowersolutions.com



ASIA

Hammond Power Solutions Pvt. Ltd.

Plot No 6A, Phase -1, IDA,
Pashamylaram, Patancheru (M)
Sangareddy, 502 307, India
Tel: +91-994-995-0009

marketing-india@hammondpowersolutions.com

EMEA (SALES OFFICE)

Hammond Power Solutions SpA

Tel: +49 (152) 08800468

sales-emea@hammondpowersolutions.com

